



Problem of the Week

Problem A and Solution

Painting Plans

Problem

Judith and James want to repaint their dining room. They have a floor plan of the dining room that shows the dimensions of the rectangular room as well as the location of the doorways.

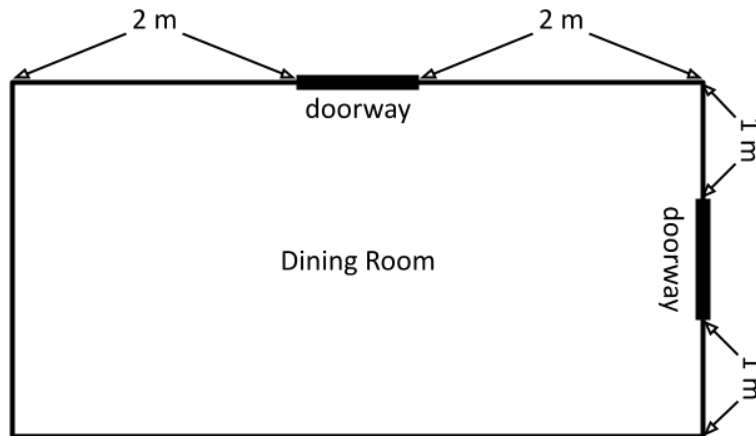

The walls are each 3 metres high and the doorways are each 2 metres high and 1 metre wide. They do not want to paint the doorways.

- For each wall, draw a diagram showing the area that needs to be painted. Show the dimensions of the walls and the doorways on each diagram.
- Calculate the total area that will be painted.

Solution

- Since the dining room is rectangular, the lengths of the opposite walls are the same. We can create a diagram of the walls based on the information from the floor plan and the known dimensions of the doorways and wall height.

From the floor plan, we know that on the longer wall with a doorway, the distance from one edge of the doorway to the edge of the wall is 2 m. We also know the width of the doorway is 1 m. Thus, the width of the entire wall is $2 + 1 + 2 = 5$ m. The longer wall without a doorway has the same width and height.



Here is a diagram of the longer walls of the dining room:

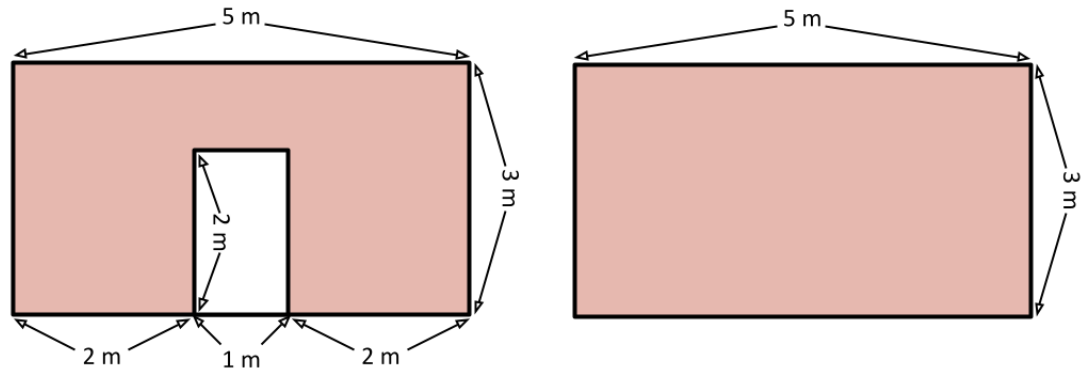

From the floor plan, we know that on the shorter wall with a doorway, the distance from one edge of the doorway to the edge of the wall is 1 m. We also know the width of the doorway is 1 m. Thus, the width of the entire wall is $1 + 1 + 1 = 3$ m. The shorter wall without a doorway has the same width and height.

Here is a diagram of the shorter walls of the dining room:

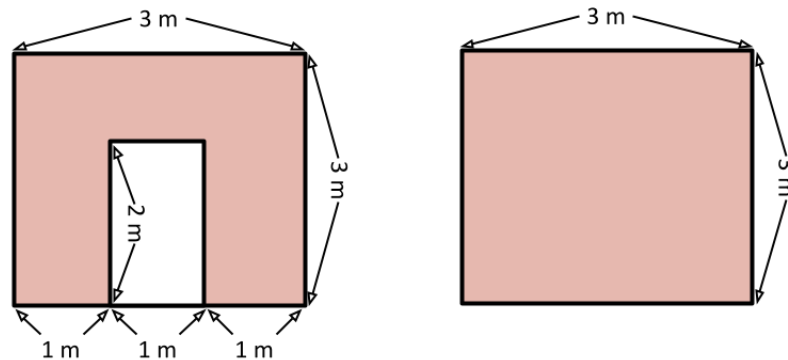

- (b) The area of the longer wall without a doorway is $5 \times 3 = 15 \text{ m}^2$. The area of the shorter wall without a doorway is $3 \times 3 = 9 \text{ m}^2$.

For the walls that include the doorways, we could divide them into rectangular pieces to determine the areas requiring paint on those walls. This means we would need to determine the dimensions of those rectangular pieces. Another way to do this is to calculate the area of the wall ignoring the doorway, and then subtract the area of the doorway to determine how much paint is required. The area of any of each doorway is $2 \times 1 = 2 \text{ m}^2$.

So the area to be painted on the longer wall with the doorway is $15 - 2 = 13 \text{ m}^2$, and the area to be painted on the shorter wall with the doorway is $9 - 2 = 7 \text{ m}^2$.

Therefore, the total area that will be painted is $15 + 9 + 13 + 7 = 44 \text{ m}^2$.